



**E.C.I.**NETWORKS

**100GBASE-ZR4 / 80KM QSFP28 Transceiver**  
**EN-QSFP28-ZR4**

**Features**

- Hot pluggable QSFP28 MSA form factor
- Compliant to IEEE 802.3ba 100GBASE-ER4
- Up to 80km reach for G.652 SMF with FEC
- Single +3.3V power supply
- Operating case temperature: 0~70oC
- 4x28G Electrical Serial Interface (CEI-28G-VSR)
- Maximum power consumption 6.5W
- Duplex LC receptacle
- RoHS-2.0 compliant
- Transmitter: cooled 4x25Gb/s LAN WDM EML TOSA (1295.56, 1300.05, 1304.58, 1309.14nm)
- Receiver: 4x25Gb/s SOA+PIN
- 



**Applications**

- 100GBASE-ZR4 100G Ethernet
- 100G Telecom Networking



## Ordering information

Part Number	Description	Data Rate	Wavelength	Distance
EN-QSFP28-ZR4-xx	QSFP28 Transceiver 100GBASE-ZR4   80KM <b>Commercial Temperature (0-+70 °C)</b>	100G	1295.56 1300.05 1304.58 1309.14	80km

## Product Selection

xx: Refers to vendor compatibility

\*\* Please note pricing is same for most of the NEMs including Cisco, Juniper, F5, Fortinet, except HP, Evertz. There is an additional charge

## Compatibility; Tested and Proven

- ◆ Proven Compatibility and Interoperability with; in process
- ◆ Test and Visibility equipment such as; IXIA, GIGAMON, VSS, SPIRENT, JDSU, XENA, EXFO, etc.

## Compliance

All our products come with Built-in digital diagnostic functions DDM Compliant with SFF-8472 Rev12 and Compliant with the QSFP28 MSA SFF SPECIFICATIONS.

## Recommended Operating Conditions and Supply Requirements

Parameter	Symbol	Min	Typical	Max	Units
Operating Case Temperature	T <sub>OP</sub>	0		70	degC
Power Supply Voltage	V <sub>CC</sub>	3.135	3.3	3.465	V
Data Rate, each Lane			25.78125		Gb/s
Control Input Voltage High		2		V <sub>CC</sub>	V
Control Input Voltage Low		0		0.8	V
Link Distance with G.652	D1			80	km



## Optical Characteristics

Parameter	Symbol	Min	Typical	Max	Unit	Notes
Lane Wavelength	L0	1294.53	1295.56	1296.59	nm	
	L1	1299.02	1300.05	1301.09	nm	
	L2	1303.54	1304.58	1305.63	nm	
	L3	1308.09	1309.14	1310.19	nm	
<b>Transmitter</b>						
SMSR	SMSR	30			dB	
Total Average Launch Power	$P_T$	7.0		12.5	dBm	
Average Launch Power, each Lane	$P_{AVG}$	1.0		6.5	dBm	
Extinction Ratio	ER	6			dB	
Difference in launch power between lanes	$P_{diff}$			3	dB	
Optical Return Loss Tolerance	TOL			20	dB	
Transmitter Reflectance	$R_T$			-12	dB	
Eye Mask{X1, X2, X3, Y1, Y2, Y3}		{0.25, 0.4, 0.45, 0.25, 0.28, 0.4}				
Average Launch Power OFF Transmitter, each Lane	$P_{off}$			-30	dBm	
<b>Receiver</b>						
Damage Threshold, each Lane	$TH_d$	-2.5		5.5	dBm	
Average Receive Power, each Lane		-28		4.5	dBm	
Receiver reflectance				-26	dB	
Difference in Receive Power between any Two Lanes (Average and OMA)	$P_{rx,diff}$			4.5	dB	
LOS Assert	LOSA	-40			dBm	
LOS Deassert	LOSD			-29	dBm	
LOS Hysteresis	LOSH	0.5			dB	



## Mechanical Specifications

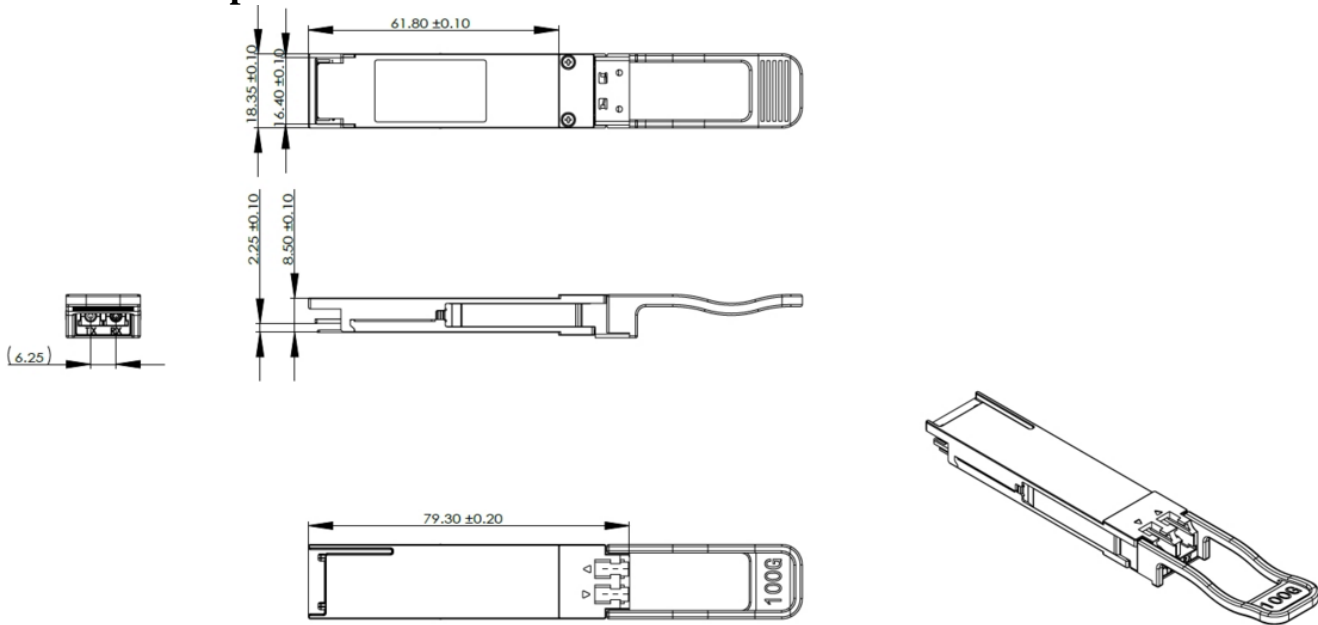

## Digital Diagnostic Monitoring Interface

The following digital diagnostic characteristics are defined over the normal operating conditions unless otherwise specified.

Parameter	Symbol	Min	Max	Units	Notes
Temperature monitor absolute error	DMI_Temp	-3	+3	degC	Over operating temperature range
Supply voltage monitor absolute error	DMI_VCC	-3%	3%	V	Over full operating range
Channel RX power monitor absolute error	DMI_RX_Ch	-3	3	dB	1
Channel Bias current monitor	DMI_Ibias_Ch	-10%	10%	mA	
Channel TX power monitor absolute error	DMI_TX_Ch	-3	3	dB	1

Notes:

1. Due to measurement accuracy of different single mode fibers, there could be an additional +/- 1 dB fluctuation, or a +/- 3 dB total accuracy.



**Notice:**

ECI Networks reserves the right to make changes to or discontinue any optical link product or service identified in this publication, without notice, in order to improve design and/or performance. Applications that are described herein for any of the optical link products are for illustrative purposes only.

For further information



**E.CI.NETWORKS**

Office: 1-800-967-1672

Fax : 1-855-201-7283

<mailto:sales@ecin.ca>