



EN-QSFP28-LR1

100G QSFP28 LR1 Transceiver

Current Document Version: V2.0

Product Features

- Compliant with IEEE 802.3cu&100G Single Lambda MSA
- Compliant with QSFP28 MSA
- Optical Interface: 106.25 Gbps (PAM4)
- Electrical Interface: 25.78 Gbps (NRZ) x 4
- 1310nm EML and PIN design
- Up to 10km over SMF with FEC
- Operating case temperature: 0 to 70°C
- Single 3.3V power supply
- Power consumption: 4.5W Max.
- LC duplex connector
- RoHS compliant

Applications

- 400G Ethernet
- Data center
- Enterprise networking

Ordering Information

| Product part Number | Media | Wavelength (nm) | Transmission Distance | Case Temperature | Data Rate |
|---------------------|-------|-----------------|-----------------------|------------------|------------|
| EN-QSFP28-LR1 | SMF | 1310 | 2m~10km | 0~70°C | 106.25Gbps |

Product Description

The optical transceiver integrates the transmit and receive path onto one module. On the transmit side, A DSP based gearbox is used to convert 4x25Gbps NRZ signals to 1x50Gbaud PAM4 signal, DSP output the PAM4 signal to laser drivers, which control one EML with 1310 nm center wavelengths. The optical signals are coupled into a single-mode fiber through an industry-standard LC connector. On the receive side, 1310nm PAM4 optical receiver data streams is coupled to a PIN PD and PAM4 transimpedance amplifier, DSP convert the PAM4 signal to 4x25G NRZ signal and output to the module electrical interface . This module features a hot-pluggable electrical interface, low power consumption, and 2-wire serial interface.



Functional Diagram

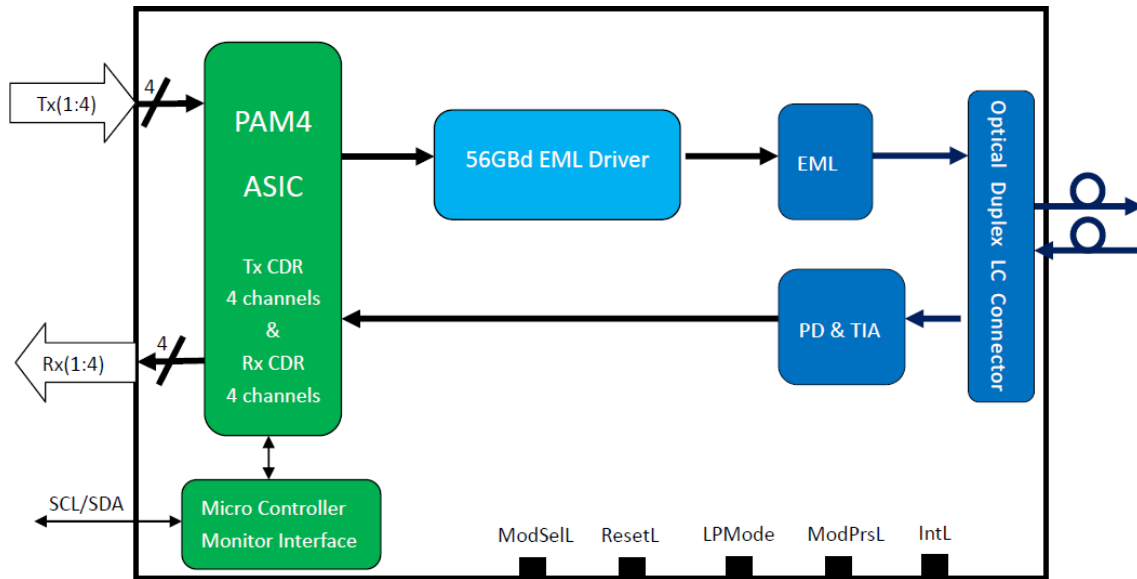

Absolute Maximum Ratings

| Parameter | Symbol | Min. | Max. | Unit | Note |
|----------------------|--------|------|------|------|------|
| Supply Voltage | Vcc | -0.5 | 3.6 | V | |
| Storage Temperature | Ts | -40 | 85 | °C | |
| Operating Case Temp. | Tc | 0 | 70 | °C | |
| Relative Humidity | RH | 15 | 85 | % | |
| Damage Threshold | THd | 5.5 | | dBm | |

Note: Stress in excess of the maximum absolute ratings can cause permanent damage to the transceiver.

Recommended Operating Conditions

| Parameter | Symbol | Min. | Typ | Max. | Unit | Note |
|-----------------------------------|--------|--------------------|-----|-------|------|------|
| Electrical Signal Rate, each lane | | 25.78125 ± 100 ppm | | | Gbps | NRZ |
| Optical Signal Rate | | 53.125 ± 100 ppm | | | GBd | PAM4 |
| Supply Voltage | Vcc | 3.135 | 3.3 | 3.465 | V | |
| Operating Case Temp. | Tc | 0 | - | 70 | °C | |
| Power Consumption | P | - | - | 4.5 | W | |
| Link Distance with G.652 | | 2- | - | 10000 | m | 1 |

Notes:

1. FEC required to be turned on to support maximum transmission distance.



Electrical Characteristics

| Parameter | Symbol | Min. | Typ | Max. | Unit | Note |
|--|---------------------------------|-------------------------------------|-----|------|------|------|
| Transmitter | | | | | | |
| Signaling rate per lane | | 25.78125 ± 100ppm | | | Gb/s | |
| Differential data input swing per lane | V _{in,pp,dif} | | | 900 | mV | |
| DC common mode voltage | | -350 | | 2850 | mV | 1 |
| Differential termination mismatch | | | | 10 | % | |
| Differential input return loss | | Per Section 83E.3.3.1, IEEE 802.3bm | | | | |
| Differential to common mode input return loss | | Per Section 83E.3.3.1, IEEE 802.3bm | | | | |
| Module stressed input test | | Per Section 83E.3.4.1, IEEE 802.3bm | | | | |
| Receiver | | | | | | |
| Signaling rate per lane | | 25.78125 ± 100ppm | | | Gb/s | |
| Differential data output swing | V _{out,pp} | | | 900 | mV | |
| DC common mode voltage | | -350 | | 2850 | mV | 1 |
| Common Mode Noise, RMS | | | | 17.5 | mV | |
| Differential termination mismatch | | | | 10 | % | |
| Eye width | | 0.57 | | | UI | |
| Eye height, differential | | 228 | | | mV | |
| Vertical eye closure | VEC | | | 5.5 | dB | |
| Transition time (20% to 80%) | t _r , t _f | 12 | | | ps | |
| Differential output return loss | | Per Section 83E.3.1.3, IEEE 802.3bm | | | | |
| Common to differential mode conversion return loss | | Per Section 83E.3.1.3, IEEE 802.3bm | | | | |

Note:

1. DC common mode voltage generated by the host. Specification includes effects of ground offset voltage.

Optical Characteristics (Under Recommended Operating Conditions)

| Parameter | Symbol | Min | Typ | Max | Unit | Notes |
|-----------------------------|----------------|------------------|-----|--------|------|-------|
| Signaling Speed | | 53.125 ± 100 ppm | | | GBd | |
| Modulation format | | PAM4 | | | | |
| Transmitter | | | | | | |
| Center Wavelength | λ _t | 1304.5 | | 1317.5 | nm | |
| Side Mode Suppression Ratio | SMSR | 30 | | | dB | |



| | | | | | | |
|--|-------------|---------------------|--|--------|-------|---|
| Average Launch Power | P_{AVG} | -1.4 | | 4.5 | dBm | 1 |
| Outer Optical Modulation Amplitude (OMA _{outer}) | P_{OMA} | 0.7 | | 4.7 | dBm | 2 |
| Transmitter and Dispersion Eye Closure for PAM4 (TDECQ) | TDECQ | | | 3.4 | dB | |
| Transmitter eye closure for PAM4 (TECQ) | | | | 3.4 | dB | 3 |
| Extinction Ratio | ER | 3.5 | | | dB | |
| Transmitter Transition Time | | | | 17 | ps | |
| Average Launch Power of OFF Transmitter | P_{off} | | | -15 | dBm | |
| RIN _{15.5OMA} | RIN | | | -136 | dB/Hz | |
| Optical Return Loss Tolerance | | | | 15.6 | dB | |
| Transmitter Reflectance | | | | -26 | dB | 4 |
| Receiver | | | | | | |
| Center Wavelength | λ_r | 1304.5 | | 1317.5 | nm | |
| Damage Threshold | THd | 5.5 | | | dBm | 5 |
| Average Receive Power | | -7.7 | | 4.5 | dBm | 6 |
| Receive Power (OMA _{outer}) | | | | 4.7 | dBm | |
| Receiver Reflectance | | | | -26 | dB | |
| Receiver Sensitivity (OMA _{outer}) | SEN | max(-6.1, SECQ-7.5) | | | dBm | 7 |
| LOS Assert | LOSA | -30 | | | dBm | |
| LOS Deassert | LOSD | | | -8 | dBm | |
| LOS Hysteresis | LOSH | 0.5 | | | dB | |

Notes:

1. Average launch power (min) is informative and not the principal indicator of signal strength. A transmitter with launch power below this value cannot be compliant; however, a value above this does not ensure compliance.
2. Even if the TDECQ < 1.4dB for an extinction ratio of ≥ 5 dB or TDECQ < 1.1dB for an extinction ratio of < 5dB, the OMA_{outer} (min) must exceed the minimum value specified here.
3. Ceq is a coefficient defined in IEEE Std 802.3-2018 clause 121.8.5.3 which accounts for reference equalizer noise enhancement.
4. Transmitter reflectance is defined looking into the transmitter.
5. The receiver shall be able to tolerate, without damage, continuous exposure to an optical input signal having this average power level. The receiver does not have to operate correctly at this input power.
6. Average receive power (min) is informative and not the principal indicator of signal strength. A received power below this value cannot be compliant; however, a value above this does not ensure compliance.
7. Receiver sensitivity (OMA_{outer}) (max) for 100GBASE-DR is informative and is defined for a transmitter with a value of SECQ up to 3.4 dB.



Pin Description

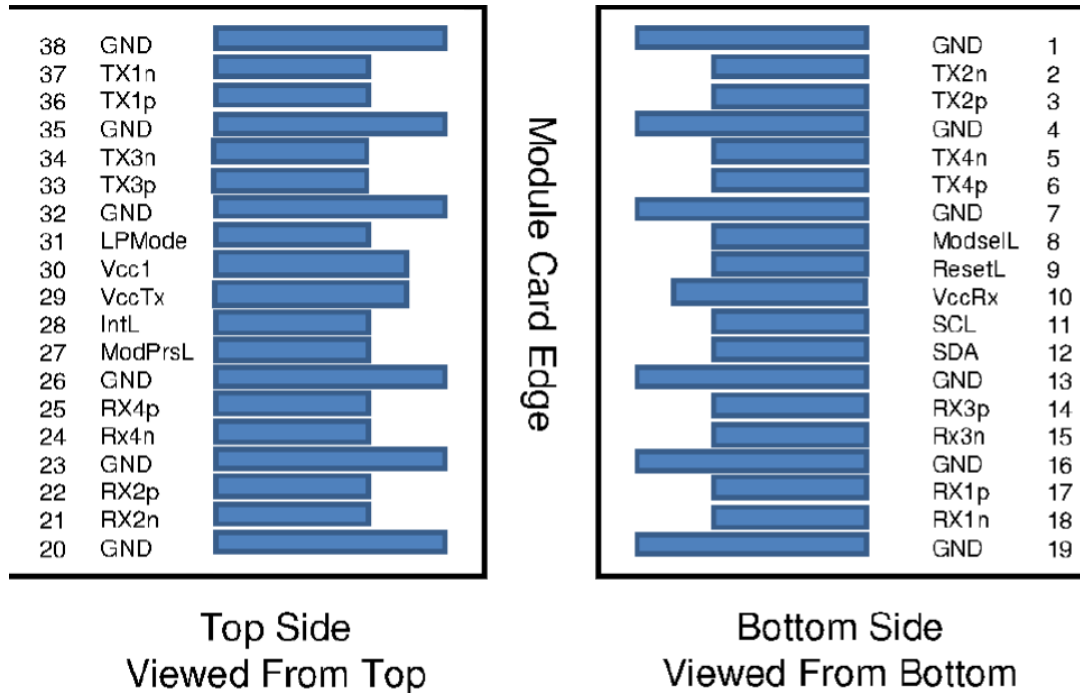

| Pin | Name | Logic | Description | Notes |
|-----|---------|-------------|-------------------------------------|-------|
| 1 | GND | | Ground | 1 |
| 2 | Tx2n | CML-I | Transmitter Inverted Data Input | 8 |
| 3 | Tx2p | CML-I | Transmitter Non-Inverted Data Input | 8 |
| 4 | GND | | Ground | 1 |
| 5 | Tx4n | CML-I | Transmitter Inverted Data Input | 8 |
| 6 | Tx4p | CML-I | Transmitter Non-Inverted Data Input | 8 |
| 7 | GND | | Ground | 1 |
| 8 | ModSelL | LVTTL-I | Module Select | 3 |
| 9 | ResetL | LVTTL-I | Module Reset | 4 |
| 10 | Vcc Rx | | +3.3V Power Supply Receiver | 2 |
| 11 | SCL | LVC MOS-I/O | 2-wire serial interface clock | 5 |
| 12 | SDA | LVC MOS-I/O | 2-wire serial interface data | 5 |
| 13 | GND | | Ground | 1 |
| 14 | Rx3p | CML-O | Receiver Non-Inverted Data Output | 7 |
| 15 | Rx3n | CML-O | Receiver Inverted Data Output | 7 |



| | | | | |
|----|---------------|---------|-------------------------------------|---|
| 16 | GND | | Ground | 1 |
| 17 | Rx1p | CML-O | Receiver Non-Inverted Data Output | 7 |
| 18 | Rx1n | CML-O | Receiver Inverted Data Output | 7 |
| 19 | GND | | Ground | 1 |
| 20 | GND | | Ground | 1 |
| 21 | Rx2n | CML-O | Receiver Inverted Data Output | 7 |
| 22 | Rx2p | CML-O | Receiver Non-Inverted Data Output | 7 |
| 23 | GND | | Ground | 1 |
| 24 | Rx4n | CML-O | Receiver Inverted Data Output | 7 |
| 25 | Rx4p | CML-O | Receiver Non-Inverted Data Output | 7 |
| 26 | GND | | Ground | 1 |
| 27 | ModPrsL | LVTTL-O | Module Present | 6 |
| 28 | IntL/Rx_LOS | LVTTL-O | Interrupt/Rx LOS | |
| 29 | Vcc Tx | | +3.3V Power supply transmitter | 2 |
| 30 | Vcc1 | | +3.3V Power supply | 2 |
| 31 | LPMODE/Tx_DIS | LVTTL-I | Low Power Mode/Tx Disable | |
| 32 | GND | | Ground | 1 |
| 33 | Tx3p | CML-I | Transmitter Non-Inverted Data Input | 8 |
| 34 | Tx3n | CML-I | Transmitter Inverted Data Input | 8 |
| 35 | GND | | Ground | 1 |
| 36 | Tx1p | CML-I | Transmitter Non-Inverted Data | 8 |
| 37 | Tx1n | CML-I | Transmitter Inverted Data Input | 8 |
| 38 | GND | | Ground | 1 |

Notes:

1. GND is the symbol for signal and supply (power) common for the module. All are common within the module and all module voltages are referenced to this potential unless otherwise noted. Connect these directly to the host board signal-common ground plane.
2. Vcc Rx, Vcc1 and Vcc Tx shall be applied concurrently. Vcc Rx Vcc1 and Vcc Tx may be internally connected within the module in any combination. The connector pins are each rated for a maximum current of 1000 mA. Recommended host board power supply filtering is shown below .
3. The ModSelL is an input pin. When held low by the host, the module responds to 2-wire serial communication commands. The ModSelL allows the use of multiple modules on a single 2-wire interface bus. When the ModSelL is "High", the module shall not respond to or acknowledge any 2-wire interface communication from the host. ModSelL signal input node shall be biased to the "High" state in the module. In order to avoid conflicts, the host system shall not attempt 2-wire interface communications within the ModSelL de-assert time after any modules are deselected. Similarly, the host shall wait at least for the period of the ModSelL assert time before communicating with the newly



selected module. The assertion and de-asserting periods of different modules may overlap as long as the above timing requirements are met.

4. The ResetL pin shall be pulled to Vcc in the module. A low level on the ResetL pin for longer than the minimum pulse length ($t_{\text{Reset_init}}$) initiates a complete module reset, returning all user module settings to their default state. Module Reset Assert Time (t_{init}) starts on the rising edge after the low level on the ResetL pin is released. During the execution of a reset (t_{init}) the host shall disregard all status bits until the module indicates a completion of the reset interrupt. The module indicates this by asserting "low" an IntL signal with the Data_Not_Ready bit negated. Note that on power up (including hot insertion) the module should post this completion of reset interrupt without requiring a reset.
5. Low speed signaling other than SCL and SDA is based on Low Voltage TTL (LVTTTL) operating at Vcc. Vcc refers to the generic supply voltages of VccTx, VccRx, Vcc_host or Vcc1. Hosts shall use a pull-up resistor connected to Vcc_host on each of the 2-wire interface SCL (clock), SDA (data), and all low speed status outputs. The SCL and SDA is a hot plug interface that may support a bus topology.
6. ModPrsL is pulled up to Vcc_Host on the host board and grounded in the module. The ModPrsL is asserted "Low" when inserted and deasserted "High" when the module is physically absent from the host connector.
7. Rx(n)(p/n) are module receiver data outputs. Rx(n)(p/n) are AC-coupled 100 Ohm differential lines that should be terminated with 100 Ohm differentially at the Host ASIC(SerDes). The AC coupling is inside the module and not required on the Host board. For operation at 28 Gb/s the relevant standards (e.g., OIF CEI v3.1) define the signal requirements on the high-speed differential lines. For operation at lower rates, refer to the relevant standards. Note: Due to the possibility of insertion of legacy QSFP and QSFP+ modules into a host designed for higher speed operation, it is recommended that the damage threshold of the host input be at least 1600 mV peak to peak differential. Output squelch for loss of optical input signal, hereafter Rx Squelch, is required and shall function as follows. In the event of the optical signal on any channel becoming equal to or less than the level required to assert LOS, then the receiver data output for that channel shall be squelched or disabled. In the squelched or disabled state output impedance levels are maintained while the differential voltage swing shall be less than 50 mVpp. In normal operation the default case has Rx Squelch active. Rx Squelch can be deactivated using Rx Squelch Disable through the 2-wire serial interface. Rx Squelch Disable is an optional function. For specific details refer to SFF-8636.
8. Tx(n)(p/n) are module transmitter data inputs. They are AC-coupled 100 Ohm differential lines with 100 Ohm differential terminations inside the module. The AC coupling is inside the module and not required on the Host board. For operation at 28 Gb/s the relevant standards (e.g., OIF CEI v3.1) define the signal requirements on the high-speed differential lines. For operation at lower rates, refer to the relevant standards. Due to the possibility of insertion of modules into a host designed for lower speed operation, the damage threshold of the module input shall be at least 1600 mV peak to peak differential. Output squelch, hereafter Tx Squelch, for loss of input signal, hereafter Tx LOS, is an optional function. Where implemented it shall function as follows. In the event of the differential, peak-to-peak electrical signal on any channel becomes less than 50 mVpp, then the transmitter optical output for that channel shall be squelched or disabled and the associated TxLOS flag set. Where squelched, the transmitter OMA shall be less than or equal to -26 dBm and when disabled the transmitter power shall be less than or equal to -30 dBm. For applications, e.g. Ethernet, where the transmitter off condition is defined in terms of average power, disabling the transmitter is recommended and for applications, e.g. InfiniBand, where the transmitter off condition is defined in terms of OMA, squelching the transmitter is recommended. In



module operation, where Tx Squelch is implemented, the default case has Tx Squelch active. Tx Squelch can be deactivated using Tx Squelch Disable through the 2-wire serial interface. Tx Squelch Disable is an optional function. For specific details refer to SFF- 8636.

Recommended Power Supply Filter

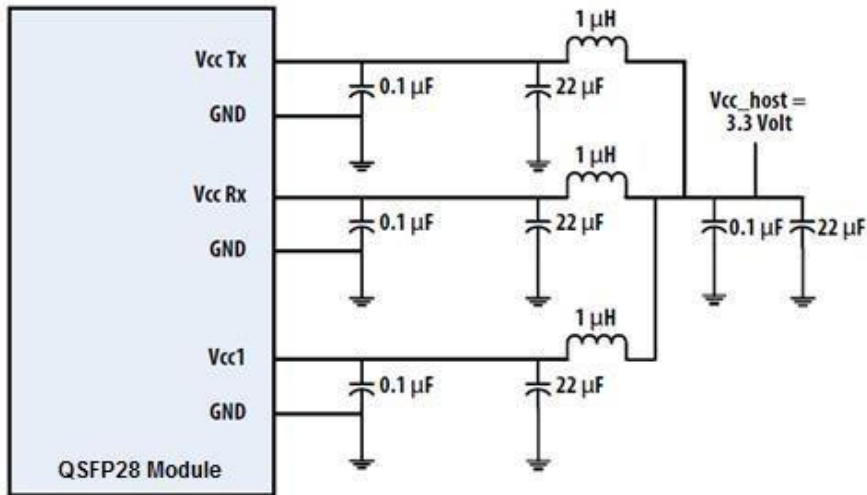

Package Dimensions

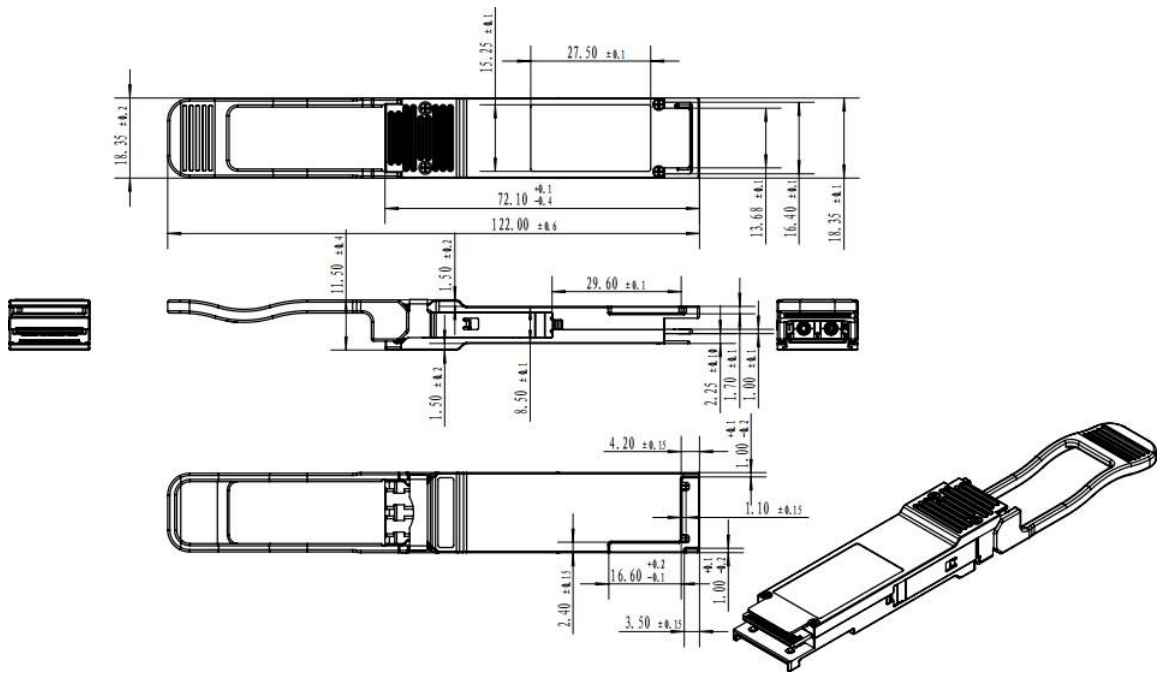

(Unit: mm)



Document Revision

| Version No. | Date | Description |
|-------------|------------|-----------------------------|
| V1.0 | 2023-10-15 | Release Preliminary Version |
| V2.0 | 2025-01-13 | Template updating |