

AT A GLANCE

E.C.I. NETWORKS's 100G Optical transceiver series include a QSFP28 10km optical transceiver that integrates the transmit and receive path onto one module.

On the transmit side, four lanes of serial data streams are recovered, retimed, and passed on to four laser drivers, which control four lasers with 1296, 1300, 1305, and 1309 nm center wavelengths. The optical signals are then multiplexed into a single-mode fiber through an industry-standard LC connector. On the receive side, four lanes of optical data streams are optically de-multiplexed by an integrated optical de-multiplexer. Each data stream is recovered by a photodetector and transimpedance amplifier, retimed, and passed on to an output driver. This module features a hot-pluggable electrical interface, low power consumption, and 2-wire serial interface

PRODUCT FEATURES

- Dual Rate 100G Ethernet and ITU-T OTU4 Compliant with 100GBASE-LR4 and ITU-T G.959.1
- Support line rates from 103.125 Gbps to 111.81 Gbps
- Duplex LC receptacle optical interface
- Transmitter: cooled 4x25Gb/s DML laser
- Receiver: 4x25Gb/s PIN receiver
- Compliant with CEI-28G-VSR
- Single +3.3V power supply
- Low power dissipation (Max:4.0W)
- Built in digital diagnostic function
- Operating case temperature range:0°C to 70°C



APPLICATIONS EXAMPLES

Usually used DCI within data centers, or across data centers for up to 10km use.

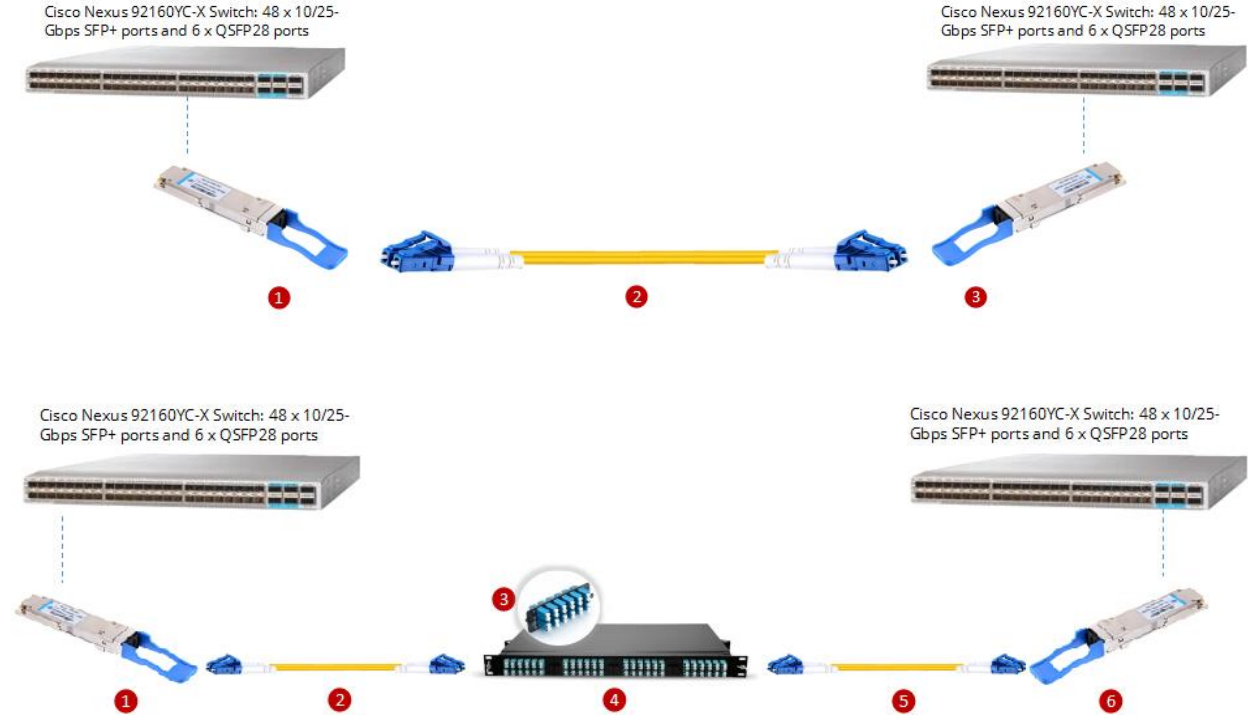

EN-QSFP28-LR4/eLR4 Direct Connectivity

The 100G-LR4/eLR4 modules use duplex LC fiber connectors – the same connectors that are used on existing 10G and 40G QSFPs that use duplex SMF (e.g. 10G-LR/ER, 40G-LR4 etc).

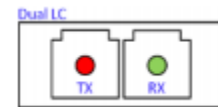
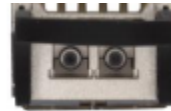

100G LR4 COB vs BOX

The 100G LR4 optics are available in two different packaging: Chip On Board (COB, non-sealed) or Hermetically sealed (BOX).

Beside operating temperature, optical components such as lasers require protection from humidity, condensation, corrosion and other environmental factors, which can all negatively affect performance and the overall life of the package. Addressing these environmental challenges is possible with hermetic packaging that creates a seal from the outside. Hermetically Sealed is highly recommended for Telco’s environment. Non-sealed is better fit for controlled environment such as Datacenter.

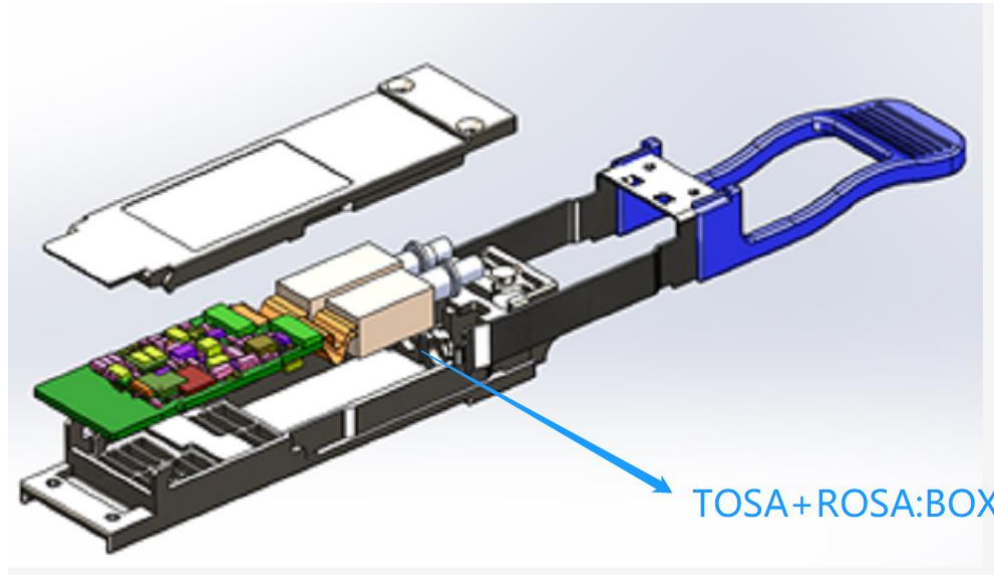

	EN-QSFP28-LR4	EN-QSFP28-LR4-S	EN-QSFP28-LR4i	EN-Q28-LR4-DR	EN-Q28-LR4-S
Packaging Technology	BOX	BOX	BOX	COB	COB
Data Rate (Max)	103.1Gbps (4x 25.78Gbps) 112Gbps (4x 28Gbps)	103.1Gbps (4x 25.78Gbps)	103.1Gbps (4x 25.78Gbps) 112Gbps (4x 28Gbps)	103.1Gbps (4x 25.78Gbps) 112Gbps (4x 28Gbps)	103.1Gbps (4x 25.78Gbps)
Cable Distance (Max)	10km @SMF	10km @SMF	10km @SMF	10km @SMF	10km @SMF

100G QSFP28 Optical Transceiver Series
QSFP28 100G 10km Transceiver
EN-QSFP28-LR4/EN-Q28-LR4

Wavelength	1295.56nm 1300.05nm 1304.58nm 1309.14nm	1295.56nm 1300.05nm 1304.58nm 1309.14nm	1295.56nm 1300.05nm 1304.58nm 1309.14nm	1295.56nm 1300.05nm 1304.58nm 1309.14nm	1295.56nm 1300.05nm 1304.58nm 1309.14nm
TX Power	-4.3~4.5dBm	-4.3~4.5dBm	-4.3~4.5dBm	-4.3~4.5dBm	-4.3~4.5dBm
Receiver Sensitivity	<-10.5dBm	<-10.5dBm	<-10.5dBm	<-10.5dBm	<-10.5dBm
Receiver Overload	4.5dBm	4.5dBm	4.5dBm	4.5dBm	4.5dBm
Max Power Consumption	4.0W	4.0W	4.0W	4.0W	4.0W
Operating Temperature	0-70°C	0-70°C	-40-85°C	0-70°C	0-70°C
Modulation Format	NRZ	NRZ	NRZ	NRZ	NRZ
Application	Telecom, Data Center, 100G Dual Rate Ethernet/112G OTN OTU4	Telecom, Data Center, 100G Ethernet only	Telecom, Data Center, 100G Ethernet/112G OTN OTU4	Data Center, 100G Ethernet/112G OTN OTU4	Data Center, 100G Ethernet Only

Ordering Information

Part Number	Description	Data Rate	Wavelength	Distance	Connector
QSFP28 (100G)					
EN-QSFP28-LR4—S-xx	Ethernet 100G QSFP28 Module 100GBASE-LR4, Single Mode, 10Km, BOX Hermetically sealed design By Default Cisco Compatible	100G	1310nm	10km	LC
EN-QSFP28-LR4-xx	Ethernet/OTU4 100G QSFP28 Module 100GBASE-LR4, Single Mode, 10Km, BOX Hermetically sealed design By Default Cisco Compatible	100G 112G	1310nm	10km	LC
EN-QSFP28-LR4i-xx	Ethernet/OTU4 100G QSFP28 Module 100GBASE-LR4, Single Mode, 10Km, Hermetically sealed BOX design By Default Cisco Compatible, Industrial Temperature	100G 112G	1310nm	10km	LC
EN-Q28-LR4-S-xx	Single Rate Ethernet 100G QSFP28 Module 100GBASE-LR4, Single Mode, 10Km, COB design By Default Cisco Compatible	100G	1310nm	10km	LC
EN-Q28-LR4-DR-xx	Dual Rate Ethernet/OTU4 100G QSFP28 Module 100GBASE-LR4, Single Mode, 10Km, COB design By Default Cisco Compatible	100G 112G	1310nm	10km	LC

Product Selection

xx: Refers to vendor compatibility

I: I refers to Industrial Temperature where applicable

Per example:

EN-SFP10G-LR-EZ refers to Commercial Temperature, and compatible with Evertz, EN-SFP10GIDL-JREX refers to Industrial Temperature, and compatible with Juniper EX Series

100G QSFP28 Optical Transceiver Series
QSFP28 100G 10km Transceiver
EN-QSFP28-LR4/EN-Q28-LR4

** Please note pricing is same for most of the NEMs including Cisco, Juniper, F5, Fortinet, except HP, Evertz. There is an additional charge

Compatibility; Tested and Proven

- ◆ Proven Compatibility and Interoperability with; TBD

Compliance

All our products come with Built-in digital diagnostic functions DDM Compliant with SFF-8472 Rev12 and Compliant with the MSA SFF SPECIFICATIONS.

ABSOLUTE MAXIMUM RATING

Stresses in excess of the absolute maximum ratings can cause permanent damage to the device. These are absolute stress ratings only. Functional operation of the device is not implied at these or any other conditions in excess of those given in the operational sections of the data sheet. Exposure to absolute maximum ratings for extended periods can adversely affect device reliability.

Parameter	Symbol	Min.	Max.	Unit	Note
Supply Voltage	V _{cc}	-0.5	3.6	V	
Storage Temperature	T _s	-40	85	°C	
Relative Humidity	R _H	0	85	%	
Rx Damage Threshold, per Lane	PR _{dmg}	5.5		dBm	

Recommended Operating Conditions

Parameter	Symbol	Min.	Typ	Max.	Unit	Note
Data Rate	DR		103.125/111.81		Gb/s	
Supply Voltage	V _{cc}	3.14	3.3	3.47	V	
Supply Current	I _{cc}			1.06	A	
Operating Case Temp.	T _c	0		70	°C	LR4
Operating Case Temp.	T _c	-40		85	°C	LR4i

Optical Characteristics (Top=0~70°C, Vcc=3.14~3.47V)

(Tested under recommended operating conditions, unless otherwise noted)

Parameter	Symbol	Unit	Min	Typ	Max	Notes
Transmitter						
Signaling rate, each lane	DR _{PL}	Gb/s	25.78125 ±100 ppm			1
Four Lane Wavelength Range	λ1	nm	1294.53	1295.56	1296.59	
	λ2		1299.02	1300.05	1301.09	
	λ3		1303.54	1304.58	1305.63	
	λ4		1308.09	1309.14	1310.19	
Total launch power	P _{out}	dBm	-	-	10.5	
Average launch power, each lane	P _{avg}	dBm	-4.3	-	4.5	2,7
Optical modulation amplitude, each lane (OMA)	OMA	dBm	-1.3	-	4.5	
Extinction ratio	ER	dB	4	-	-	
Side-mode suppression ratio	SMSR	dB	30	-	-	
Average launch power of OFF transmitter, per lane	POFF	dBm	-	-	-30	
Relative Intensity Noise	RIN	dB/Hz			-130	
Optical return loss tolerance	ORLT	dB	-	-	20	
Transmitter reflectance	TR	dB	-	-	-12	
Transmitter eye mask {X1, X2, X3, Y1, Y2, Y3}	M _t		{0.25, 0.4, 0.45, 0.25, 0.28, 0.4}			3
Receiver						
Receive Rate for Each Lane	DR _{PL}	Gb/s	25.78125 ±100 ppm			4
Four Lane Wavelength Range	λ1	nm	1294.53	1295.56	1296.59	
	λ2		1299.02	1300.05	1301.09	
	λ3		1303.54	1304.58	1305.63	
	λ4		1308.09	1309.14	1310.19	
Overload Input Optical Power	P _{max}	dBm	5.5	-	-	
Average Receive Power for Each Lane	P _{in}	dBm	-10.6	-	4.5	5,7
Receiver sensitivity (OMA), each lane	P _{sens1}	dBm	-	-	-8.6	
Stressed Sensitivity(OMA) , each lane	P _{sens2}	dBm	-	-	-6.8	6

Return Loss	RL	dB	-26	-	-	
Receiver Electrical 3dB upper cutoff frequency, per lane	F3db	GHz	-	-	31	
Los De-Assert	P _d	dBm	-	-	-11.6	
Los Assert	P _a	dBm	-23.6	-	-	
Loss Hysteresis	P _d -P _a	dBm	0.5	2	6	

Notes:

1. Transmitter consists of 4 lasers operating at 25.78Gb/s each.
2. Minimum value is informative.
3. Hit ratio 5x10⁻⁵.
4. Receiver consists of 4 photodetectors operating at 25.78Gb/s each.
5. Minimum value is informative, equals min TxOMA with infinite ER and max channel insertion loss.
6. SRS is measured with vertical eye closure penalty of 1.8 dB max, J2 of 0.30 UI, and J9 of 0.47 UI.
7. Power value and power accuracy are with all channels on..

Mechanical specifications

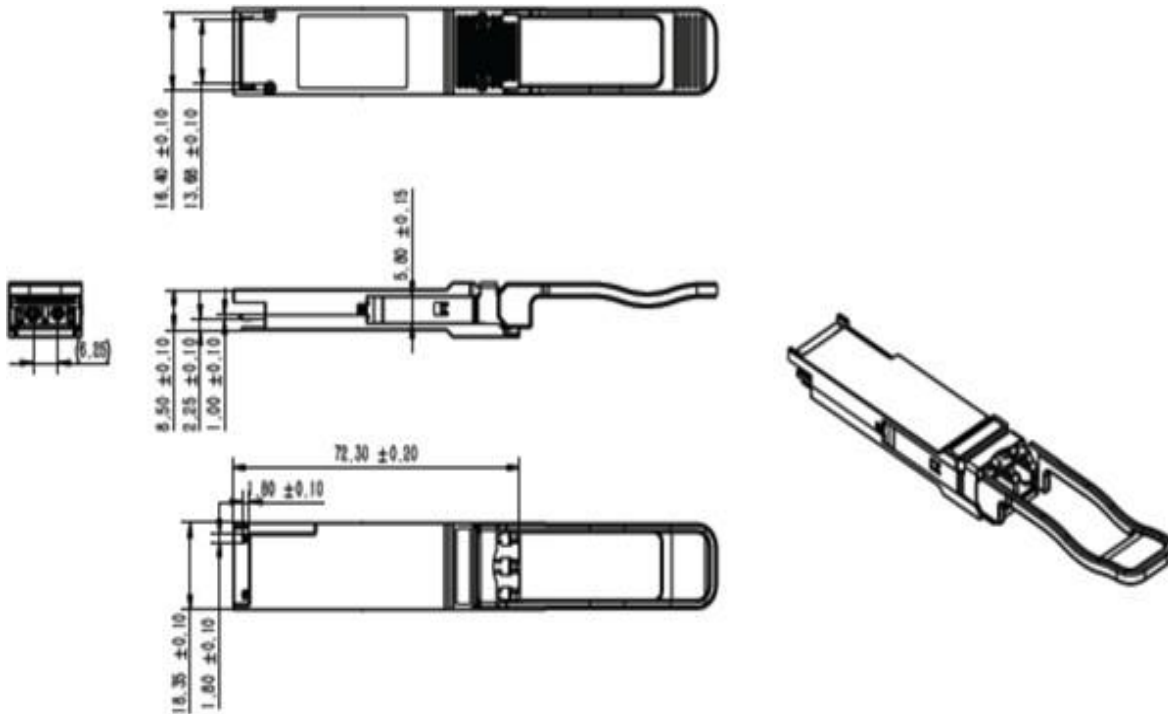

Regulatory Compliance

Feature	Reference	Performance
Electrostatic discharge (ESD)	IEC/EN 61000-4-2	Compatible with standards
Electromagnetic Interference (EMI)	FCC Part 15 Class B EN 55022 Class B (CISPR 22A)	Compatible with standards
Laser Eye Safety	FDA 21CFR 1040.10, 1040.11 IEC/EN 60825-1, 2	Class 1 laser product
Component Recognition	IEC/EN 60950, UL	Compatible with standards
ROHS	2002/95/EC	Compatible with standards
EMC	EN61000-3	Compatible with standards

Notice:

ECI Networks reserves the right to make changes to or discontinue any optical link product or service identified in this publication, without notice, in order to improve design and/or performance. Applications that are described herein for any of the optical link products are for illustrative purposes only.

For further information



Office: 1-800-967-1672

Fax : 1-855-201-7283

<mailto:sales@ecin.ca>